



Short Description



- Nickel plated alloy steel IP67 shear beam load cell (100kg & 250kg are bending beam load cells)
- Suitable for platform weighing, container and tank scales, bed weighing, etc.
- High accuracy
- High reliability
- Current calibrated (SC-option)
- Optional T-hole force introduction available (W6 version)
- Optionally with through hole (W4 version)



Test certificate no. TC8012 Revision 1
C of C no R60/2000-NL1-12.12



Certificate no. 12-028

Available Models

Capacity	Accuracy	Full Article Description
100kg	C3/C4/C5	H8C-C3/C4/C5-100kg-4B(-SC-W6)
250kg	C3/C4/C5	H8C-C3/C4/C5-250kg-4B(-SC-W6)
500kg	C3/C4/C5	H8C-C3/C4/C5-500kg-4B(-SC-W6)
750kg 1t	C3/C4/C5	H8C-C3/C4/C5-750kg-4B(-SC-W6)
1.5t 2t	C3/C4/C5	H8C-C3/C4/C5-1.0t-4B(-SC-W6)
2.5t 3t 5t	C3/C4/C5	H8C-C3/C4/C5-1.5t-4B(-SC-W6)
10t	C3/C4/C5	H8C-C3/C4/C5-2.0t-4B(-SC-W6)
	C3/C4/C5	H8C-C3/C4/C5-2.5t-6B(-SC-W6)
	C3/C4/C5	H8C-C3/C4/C5-3.0t-6B(-SC-W6)
	C3/C4/C5	H8C-C3/C4/C5-5.0t-6B(-SC-W6)
	C3/C4/C5	H8C-C3/C4/C5-10t-6B(-SC-W6)

Marketed by:

Kanta King Technologies Pvt. Ltd.

C-25, 2nd Floor, DSIDC Complex, Kirti Nagar,
New Delhi - 110015, INDIA



+91.9560915555



info@kantaking.com



www.kantaking.com



Type H8C Load Cell

Technical Specifications H8C

Accuracy Class		OIML R60 C3	OIML R60 C4	OIML R60 C5
Output Sensitivity (= FS)	mV/V	3.0 ± 0.003		
Maximum Capacity (Emax)	t	0.1, 0.25, 0.5, 0.75, 1, 1.5, 2, 2.5, 3, 5, 10	0.1, 0.25, 0.5, 0.75, 1, 1.5, 2, 2.5	3, 5, 10
Max. Number of Load Cell Intervals	nLC	3000	4000	5000
Ratio of min. LC Verification Interval	$Y = E_{max} / n^{1.5}$	10000	15000	20000 18000
Combined Error	%FS	≤± 0.023	≤± 0.0175	≤± 0.014
Creep Error (30 minutes)	%FS	≤± 0.016	≤± 0.012	≤± 0.010
Temperature Effect on Zero (ZTC)	%FS/10°C	≤± 0.015	≤± 0.010	≤± 0.007
Temperature Effect on Sensitivity (STC)	%FS/10°C	≤± 0.011	≤± 0.009	≤± 0.008
Zero Balance	%FS	≤± 1.0		
Safe Overload	%FS	150		
Ultimate Overload	%FS	300		
Maximum Deflection	mm	0.1t – 0.2t: 0.3	0.5t – 5t: ~ 1.2	10t: 0.8
Excitation, Recommended Voltage	V	5 ~ 12		
Excitation, Maximum Voltage	V	18		
Input Resistance	Ω	350 ± 3.5		
Output Resistance	Ω	350 ± 3.5		
Insulation Resistance (50V)	MΩ	≥5000		
Compensated Temperature	°C	-10 ~ + 40		
Operating Temperature	°C	-35 ~ + 65		
Storage Temperature	°C	-40 ~ + 80		
Load Cell Weight	kg	0.1t – 2.0t: ~ 0.9	2.5t – 5t: ~ 1.7	10t: ~ 3.6
Element Material		Nickel plated alloy steel		
Ingress Protection (acc. to EN 60529)		IP67		
Recommended Torque on Fixation Bolts	Nm	M12: 100	M18:200	M24:700
ATEX Classification (optional)		II 1G Ex ia IIC T4 Ga	II 1D Ex ia IIIC T ₂₀₀ 135°C Da	II 3G Ex ic IIC T4 Gc

Wiring

Features:

Cable type: Shielded, 4 or 6 conductor cable, conductor AWG 22 (4-wire) & AWG 24 (6-wire)

Cable diameter: Ø 5.0mm

Cable length: 4m for 100kg – 2t; 6m for higher capacities

Cable jacket: Polyurethane

Shield not connected to element

4-Wire Connection Diagram

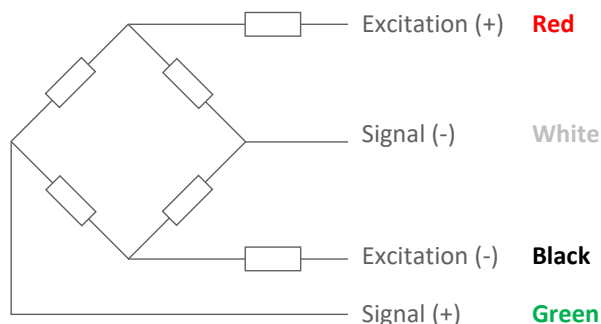

6-Wire Connection Diagram

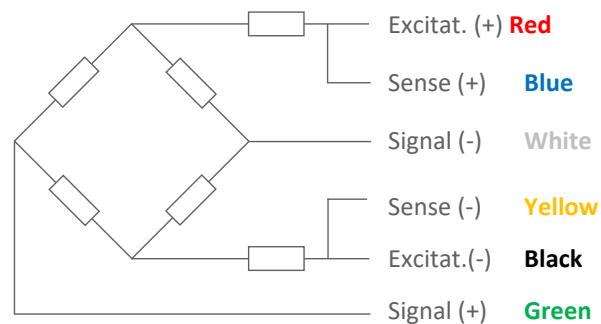

Marketed by:

Kanta King Technologies Pvt. Ltd.

C-25, 2nd Floor, DSIDC Complex, Kirti Nagar,
New Delhi - 110015, INDIA



+91.9560915555



info@kantaking.com



www.kantaking.com

Type H8C Load Cell

Ordering Info

H8C - C3 - 1.0t - 4 - - BX - SC - XX

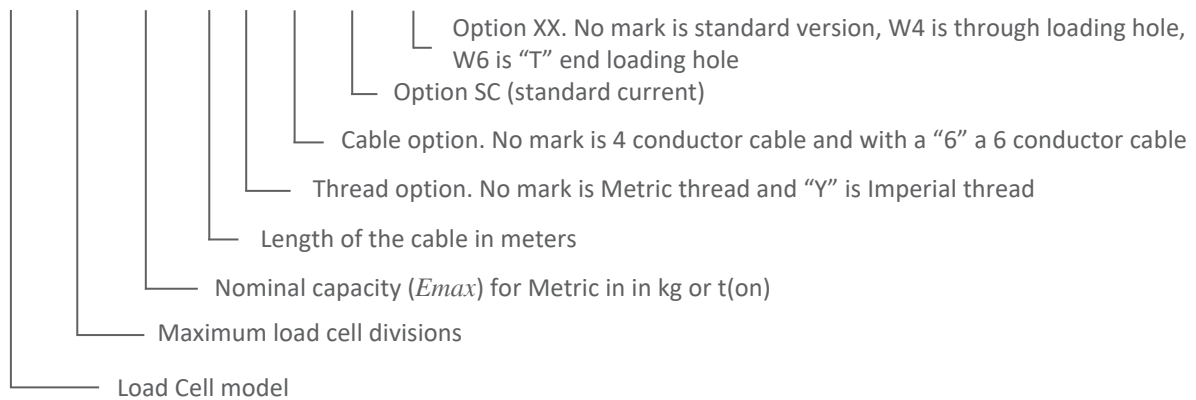

Dimensions in mm

Standard Version

Side View

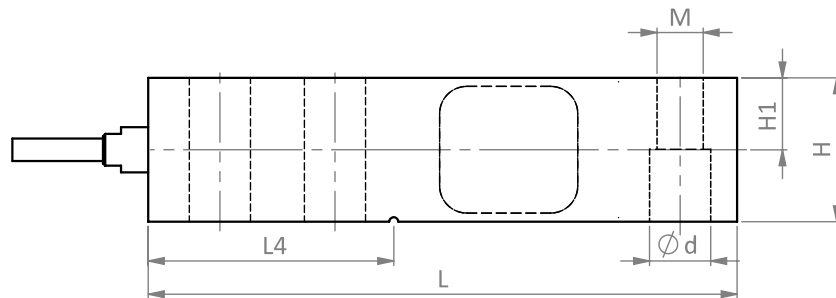

Top View

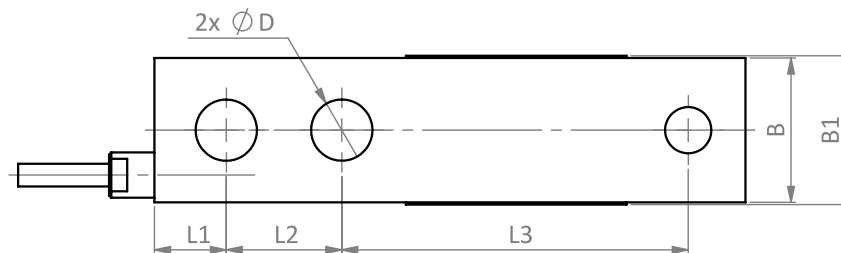

Isometric View

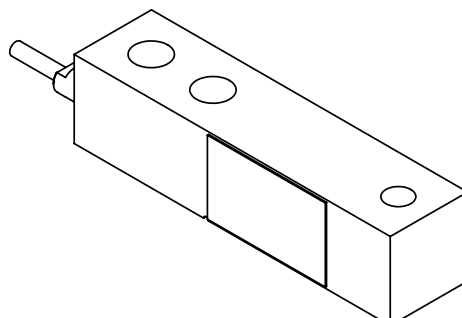



KANTAKING[®]
ACCURATE WEIGHT BRINGS PROFIT

Type H8C Load Cell

Option W6 version ("T" end loading hole)

Side View

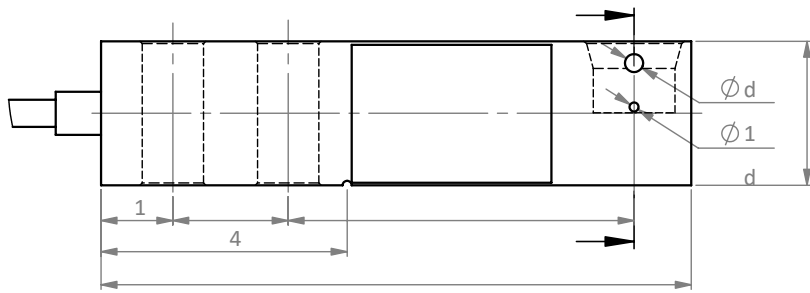

Front View

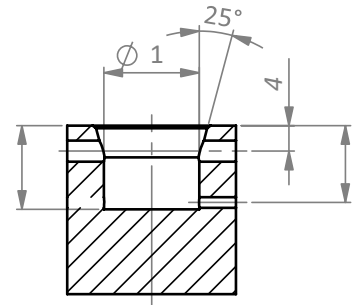

Top View

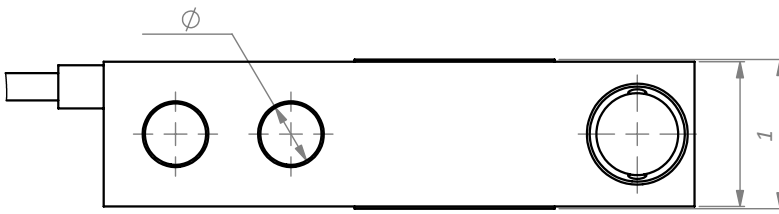

Isometric View

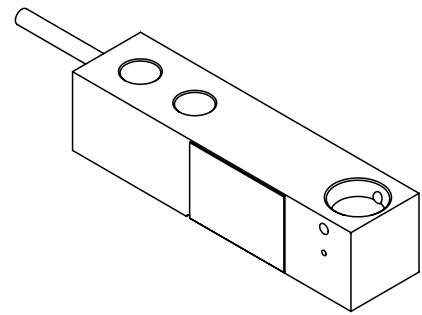

Capacity Dimension	100kg – 250kg	0.5t – 2t	2.5t – 5t	10t
L	130	130	171.5	222.3
L1	15.8	15.8	19.1	25.4
L2	25.4	25.4	38.1	50.8
L3	76.2	76.2	95.3	120.7
L4	54.2	54.2	77.2	101.6
B	31.8	31.8	38.1	50.8
B1	37	34	40	52.4
H	31.8	31.8	38.1	50.8
H1	15.8	15.8	18.8	25.4
H2	14.5	14.5	17.5	-
H3	15.8	15.8	18.8	-
H4	4.8	4.8	4.8	-
ϕD	13.5	13.5	19.8	26
$\phi D1$	18	18	25	-
$\phi d1$	4	4	4	-
$\phi d2$	2	2	2	-
M	12 x 1.75	12 x 1.75	18 x 1.5	24 x 2

Marketed by:
Kanta King Technologies Pvt. Ltd.
C-25, 2nd Floor, DSIDC Complex, Kirti Nagar,
New Delhi - 110015, INDIA

+91.9560915555
info@kantaking.com
www.kantaking.com

Type H8C Load Cell

Available Accessories

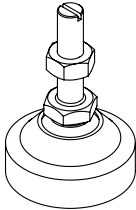
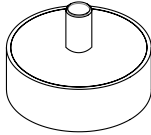
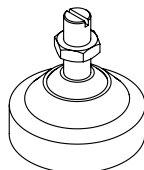
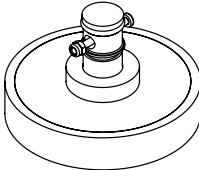
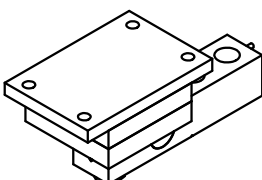
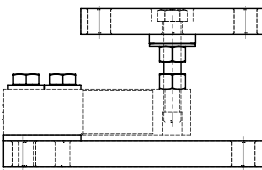
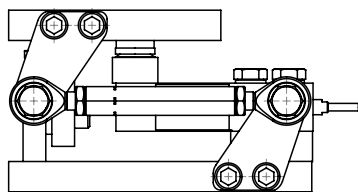
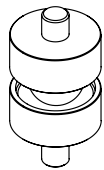
<p>HJ-8-201-0.1t/2t & 2.5t/5t & 10t Foot</p> <ul style="list-style-type: none"> • \varnothing 60-80-86mm and height 92-105-112 mm • Nickel plated alloy steel • Adjustable height • Self-centering 	
<p>HJ-8-203-0.1 – 2t Foot</p> <ul style="list-style-type: none"> • \varnothing 67mm and height 46 mm • Nickel plated alloy steel • Very easy installation 	
<p>HJ-8-213-0.1 – 2t Low Profile Foot</p> <ul style="list-style-type: none"> • \varnothing 60mm and height 64 mm • Nickel plated alloy steel • Adjustable height 	
<p>HJ-8-236-0.1 – 5t Foot (for -W6 type)</p> <ul style="list-style-type: none"> • \varnothing 60/80/125mm and height 41-50/70-91 mm • Zinc plated alloy steel • Adjustable height 	
<p>Elastomer H8C 0.1 – 2t/5t/10t</p> <ul style="list-style-type: none"> • Suitable for shock load • 3 Different versions for various capacities • Easy installation 	
<p>HM-8-402-0.1 – 2t/2.5 – 5t/10t Mount</p> <ul style="list-style-type: none"> • Nickel plated alloy steel • Adjustable mounting height • Easy installation 	
<p>HM-8-901-0.1t – 2t/2.5t – 5t Mount</p> <ul style="list-style-type: none"> • Nickel plated alloy steel • Lift-off and horizontal movement protection • Easy installation, including load cell dummy 	
<p>HY-8-102-0.1 – 5t Ball Foot</p> <ul style="list-style-type: none"> • Nickel plated alloy steel • Easy installation • Good self-alignment ability 	
<p>HD-8-301-0.1 – 2t/2.5 – 5t/10t Spacer Plate</p> <ul style="list-style-type: none"> • Nickel plated alloy steel spacer plate • 3 Different sizes for various capacities 	